

AVL Tracking System

TR-606D

GlobalSat WorldCom Corporation

16F., No. 186, Jian 1st Rd, Zhonghe Dist.,
New Taipei City 23553, Taiwan
Tel: 886.2.8226.3799/ Fax: 886.2.8226.3899
service@globalsat.com.tw
www.globalsat.com.tw

USGlobalSat Incorporated

14740 Yorba Court Chino, CA 91710
Tel: 888.323.8720 / Fax: 909.597.8532
sales@usglobalsat.com
www.usglobalsat.com

CONTENT

1. Introduction	3
1.1 Introduction.....	3
1.2 Features	3
1.3 Hardware Architecture	4
1.4 Hardware specification	5
1.5 Appearance	6
1.6 LED indicator.....	7
1.7 Cable description	8
1.8 Accessories	10
2 Operation.....	11
2.1 Install the SIM card.....	11
2.2 Install the GPS and 3G antenna.....	12
2.3 Installing the Emergency button.....	13
2.4 Connecting the Main Power.....	14
2.5 Connecting ignition detection line on car/asset.....	15

1. Introduction

1.1 Introduction

The TR-606D is a multi-functional and economically feasible communication platform for mobile positioning applications. It integrates highly sensitive GPS module, dual-band UMTS/HSDPA and quad-band GSM communication module with a powerful microcontroller that fits into a compact enclosure. The TR-606D has a solid and rigid housing, for simple installation. It provides real-time GPS positions anytime and anywhere with an open view to the sky, and offers precise positioning, and reports vehicle status to the server with necessary information shown on the map. Benefits such as enhanced fleet management, improved vehicle safety, emergency response, are all accomplished through the implementation of the TR-606D system.

1.2 Features

- Dual-Band UMTS/HSDPA 900/2100 MHz WCDMA system
- Quad-band GSM/GPRS/EDGE 850/900/1800/1900 MHz system
- Built in high sensitivity GPS system
- Supports AT command via SMS/ TCP/UDP
- Remote control via SMS/GPRS command
- Real-time GPS position feedback and vehicle status monitoring
- Built-in digital outputs (3), digital inputs (3), an ACC input, 1 analog input, and 1 serial port
- Power supply for Li-ion battery and lead-acid battery
- Supports multi geo-fence function
- OTA (Over the air) firmware upgrade
- Data buffer storage 3,000 points
- Interval report depends on customization
- Power low/lost detection alarm
- Motion sensor
- 3 LED indicators for 3G, GPS, power status

1.3 Hardware Architecture

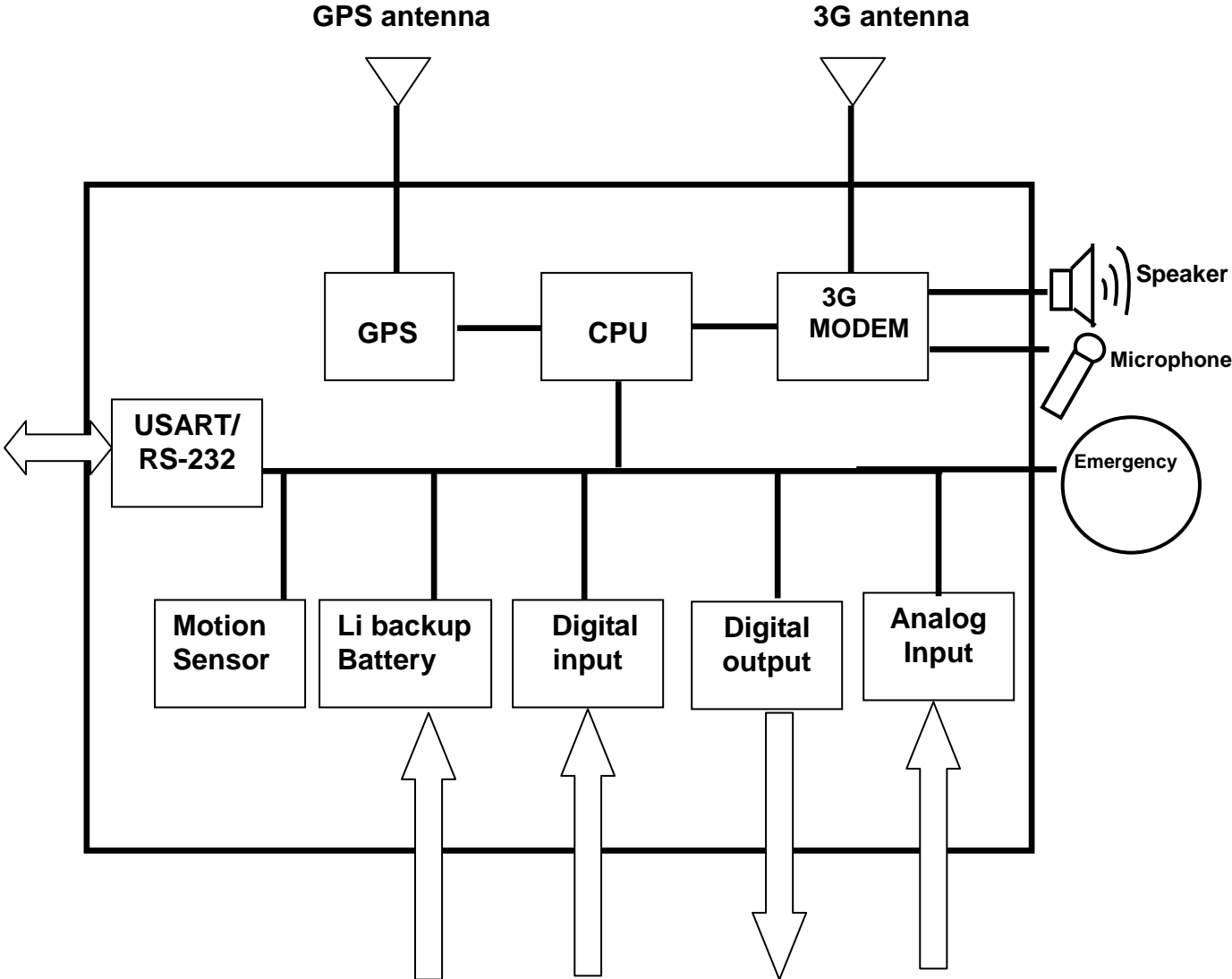

1.4 Hardware specification

Item	Description	
Dimension	98 mm X 71 mm X 22 mm	
CPU	High performance line ARM-base 32-bit MCU	
GPS receiver	High Performance GPS chipset	
Temperature	Operation	-30°C ~ + 80°C
	Storage	-40°C ~ + 85°C
GPS Antenna	SMA Type connector. Active antenna (3.3~3.8V)	
3G Antenna	SMA Type connector.	
Communication	UMTS/HSDPA 900/2100 MHz WCDMA Quad-Band GSM/GPRS/EDGE 850/900/1800/1900 MHz	
Protocol	Voice/SMS/GPRS (TCP/UDP)	
Built-in Memory	32 Mb	
GPS logging capacity	3000 points (Cell ID 1,400 points)	
Emergency Input	Negative trigger	1
Ignition (ACC) Input	Positive trigger	1
Digital Input Port	Negative trigger	2
	Positive trigger	1
Digital Output Port	Negative trigger	3 (300 mA)
Analog Input Port	Analog Input	1(0~28V)
Serial Port	115200 bps	
Backup battery	Internal 820 mAh Lion battery Support external Lead-acid battery (12V/24V)	
Sensor	Motion sensor	

1.5 Appearance

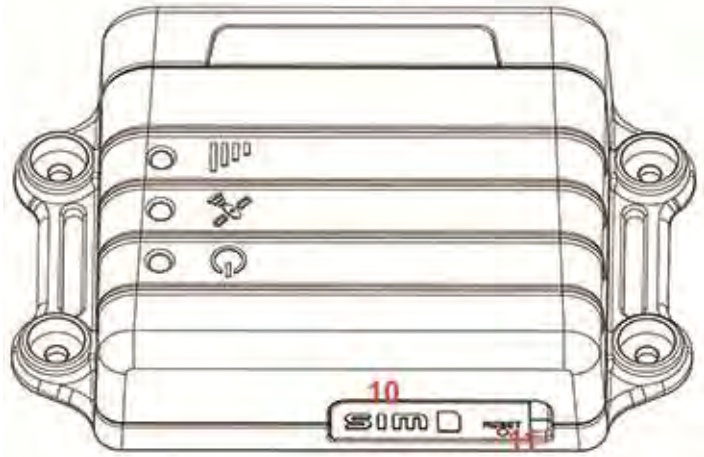
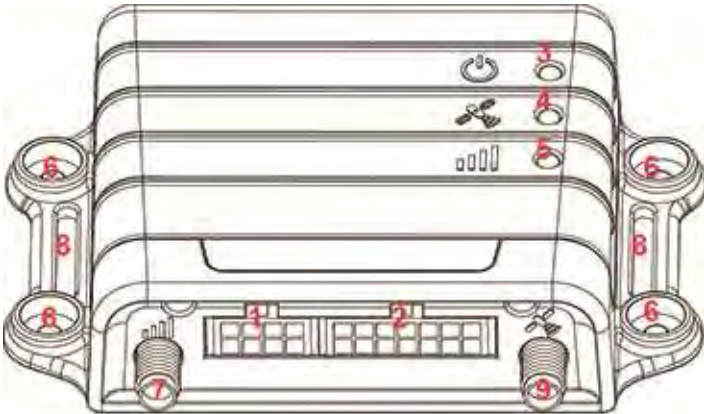

1	Peripheral interface port
2	I/O port
3	Power Status LED
4	GPS LED
5	3G LED
6	For fixing device with screws
7	3G antenna connector
8	For fixing device with belt
9	GPS antenna connector
10	SIM card holder
11	Reset Button

1.6 LED indicator

Power Status LED (Red)

LED	Permanently On
State	Main power on, device on

GPS LED (Yellow)

LED	Permanently off	Fast blinking (Once every 1 second)	Slow blinking (Once every 3 seconds)
State	GPS off	GPS not fix	GPS fix

3G LED (Green)

LED	Permanently off	Fast blinking (Once every 1 second)	Slow blinking (Once every 3 seconds)
State	3G off	<ol style="list-style-type: none"> 1. TR-606D is searching 3G network 2. SIM card is registering to 3G network 	TR-606D is registered full service

1.7 Cable description

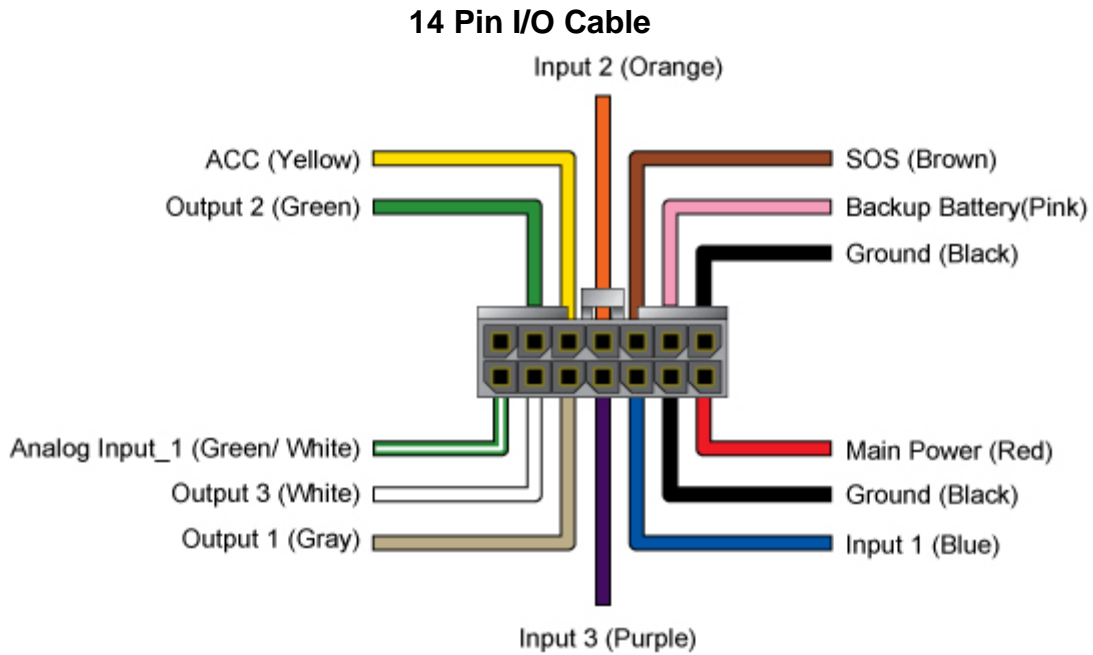

Wire Color	Description
Green/ White	Analog Input_1
White	Digital Output 3 (Negative Trigger)
Gray	Digital Output 1 (Negative Trigger)
Purple	Digital Input 3 (Positive Trigger)
Blue	Digital Input 1 (Negative Trigger)
Black	Ground
Red	Main Power
X	
Green	Digital Output 2 (Negative Trigger)
Yellow	ACC (Positive Trigger)
Orange	Digital Input 2 (Negative Trigger)
Brown	Emergency (Negative Trigger)
Pink	12V/24V Backup Battery
Black	Ground

8 Pin Cable

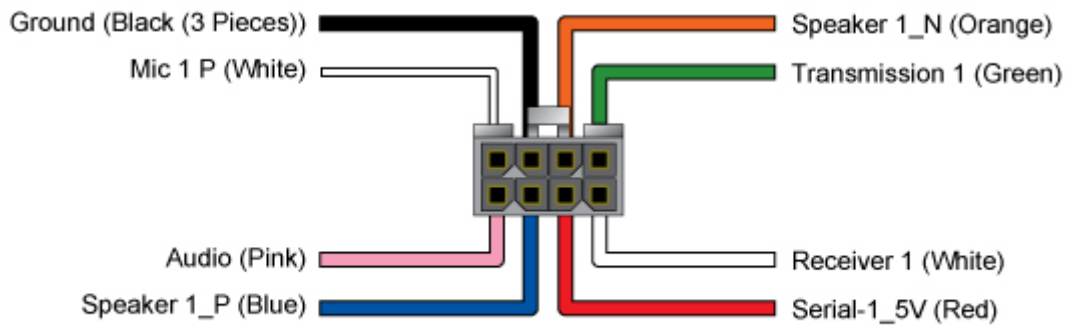

Wire Color	Description
Pink	Audio_5V
Blue	Speaker 1(Positive)
Red	Serial-1_5V
White	Receiver 1
White	Microphone 1 P
Black (3 Pieces)	Ground
Orange	Speaker 1(Negative)
Green	Transmission 1

1.8 Accessories

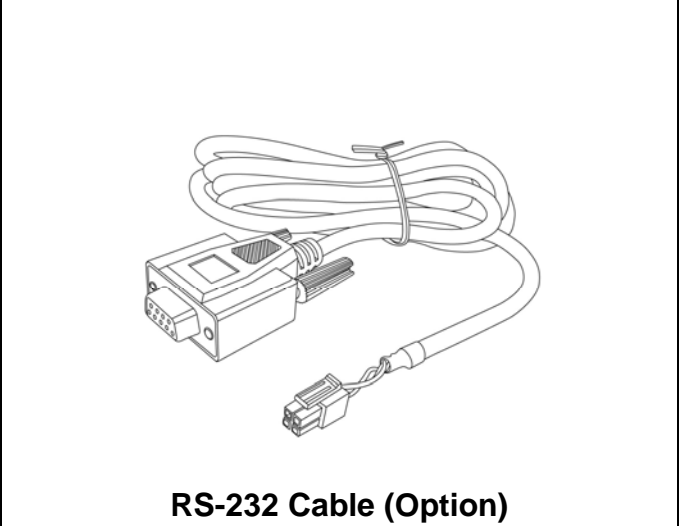
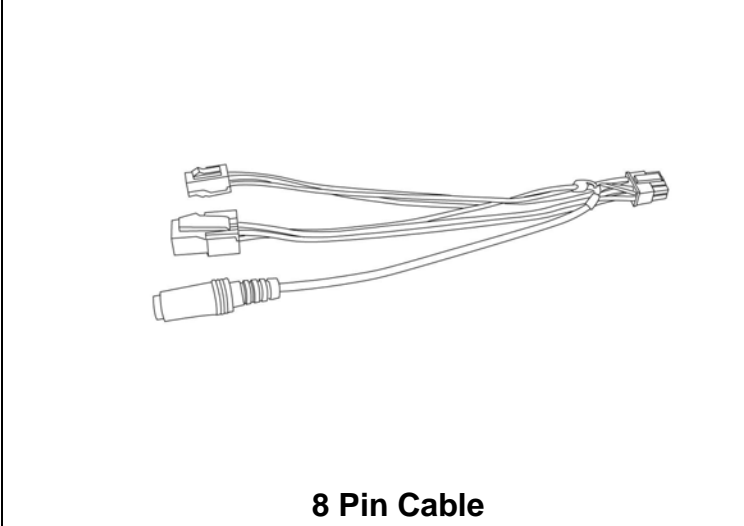
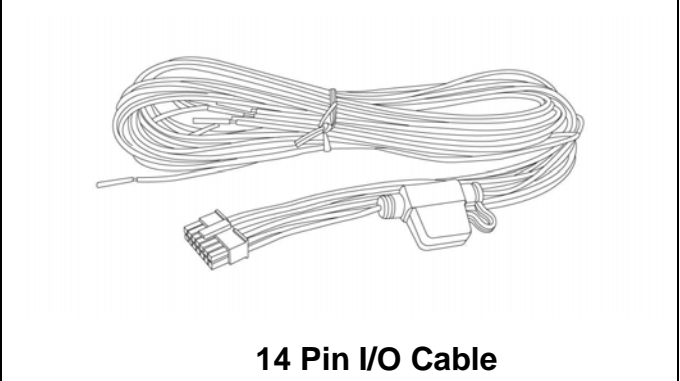
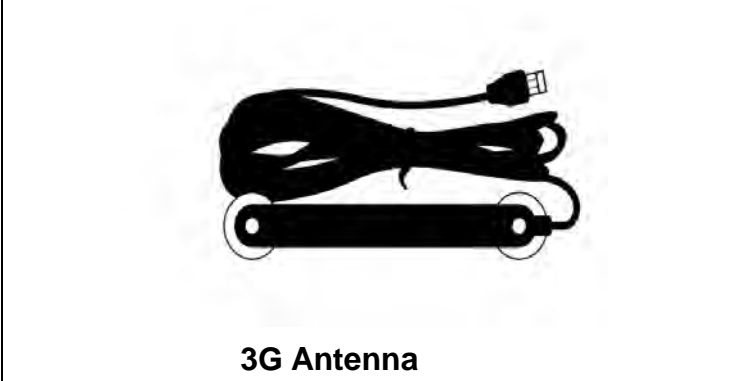
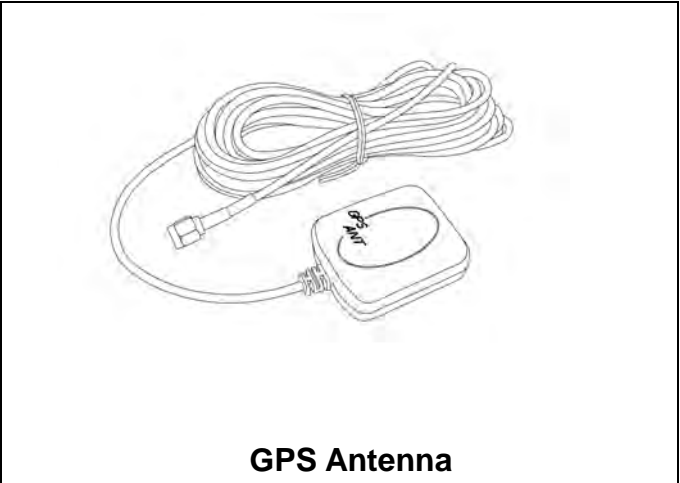
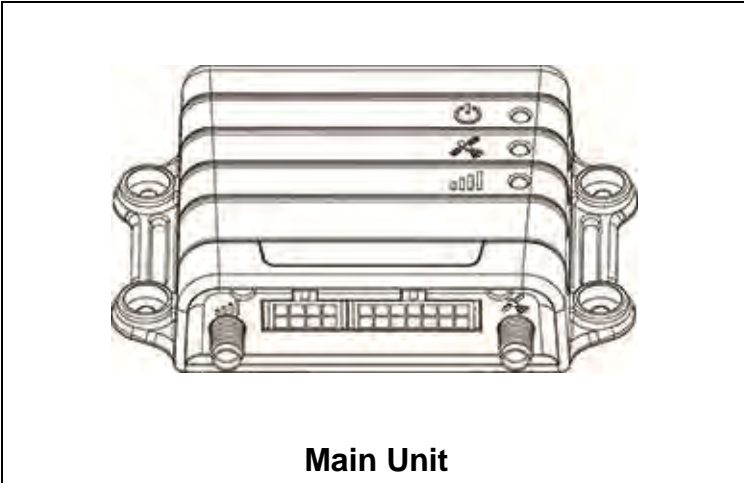

2 Operation

For first time users, please follow the steps below to complete the pre-installation.

2.1 Install the SIM card



With the copper contacts facing up, align the notch on the SIM card with the notch on the SIM slot and insert the SIM card. If SIM is inserted correctly, you will not be able to see the copper contacts after inserting the card. To eject SIM card, simply, use your finger nail and apply slight pressure.

Note: Make sure to disable the SIM PIN entry function on the SIM card before inserting your SIM card

Note: Before installing or taking out the SIM card, please power off the TR-606.

2.2 Install the GPS and 3G antenna



Install the 3G antenna to the 3G antenna port on the left side of the front of the device. Install the GPS antenna to the GPS antenna port on the right side of the front of the device.

Make sure both antennas tightly screwed in place. Please refer to the photo above.

2.3 Installing the Emergency button

There is a line of the 14 pin IO cable for connecting push button for emergency help.

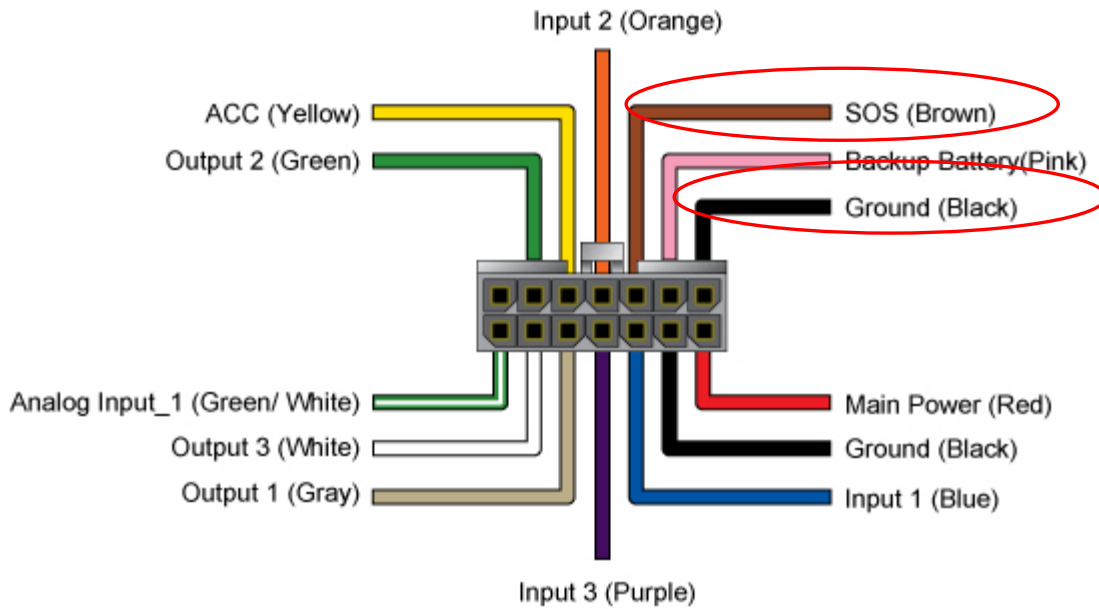

One end of the button must be connected to the emergency line and the other end must be connected to the ground line.

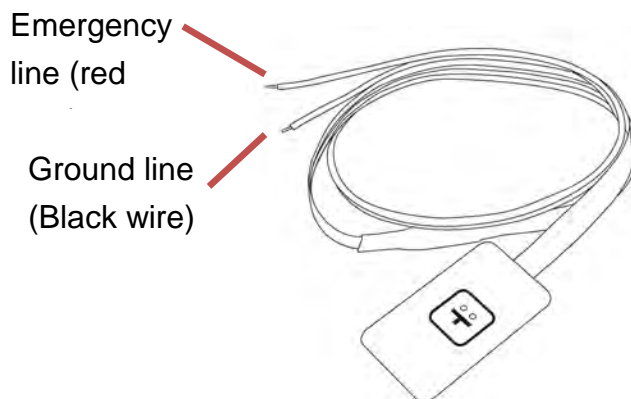

2.4 Connecting the Main Power

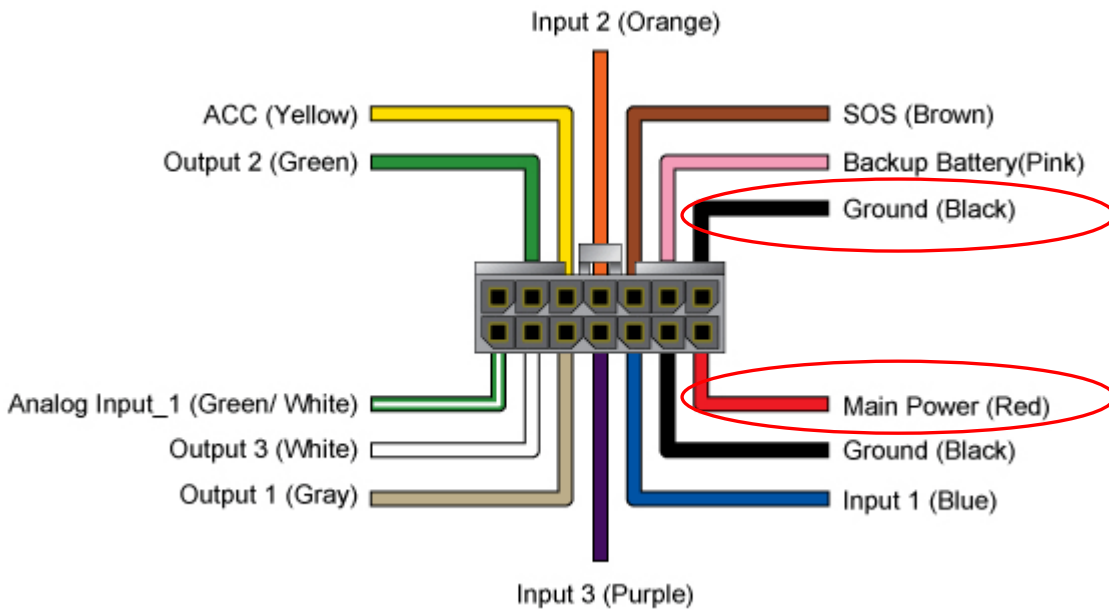

Connect the red wire from the cable to a power source of 10~36 V. Connect the black wire to ground.

Note: Please make sure the external power is well connected to TR-606D.

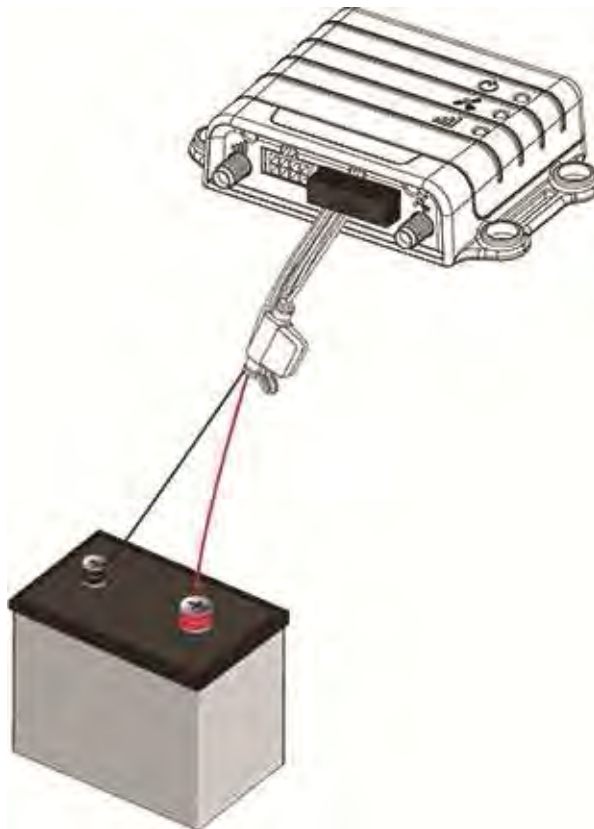

2.5 Connecting ignition detection line on car/asset

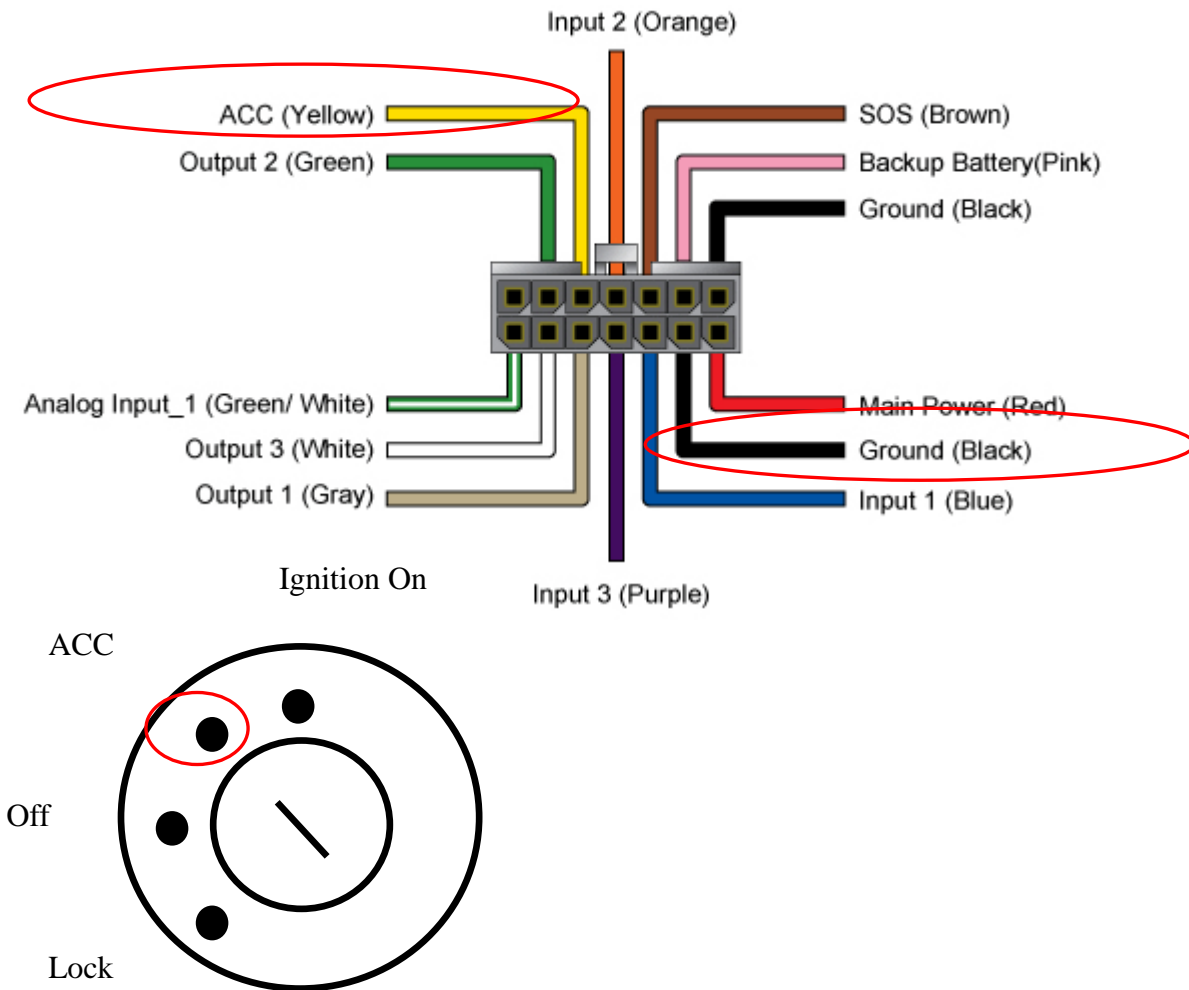

Connect the yellow wire from the cable to ACC/ignition (12V) position of vehicle/asset.
Connect the black wire to ground.

Installation Notice of TR-606D:

Notice:



The GPS signal and 3G signal would be significantly reduced or fully blocked by the metal shielding material. In order to have the device work properly, please avoid installing in metal shielding environments. E.g. sealed metal box.

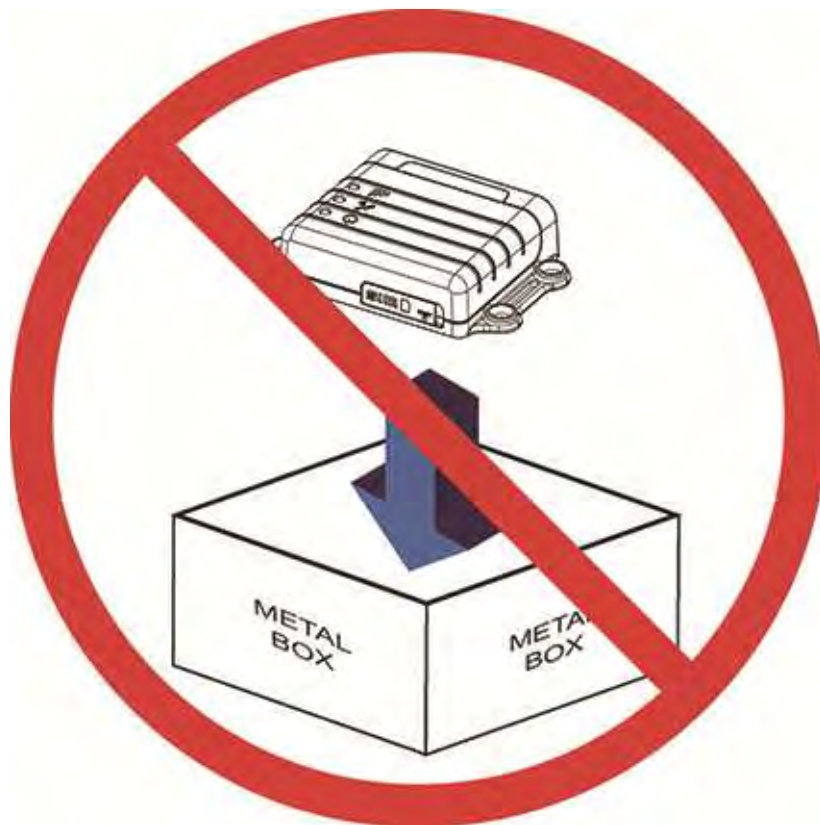

Notice:



GPS device must be placed under open sky condition to achieve the best performance. Indoor installation will severely degrade the signal and result in location fixing failure.



Notice:



Please use TR-606D in the area with stable GPRS/UMTS coverage area.

